



# NE-1025

## 1000 Watt\* Commercial Microwave Oven

- Stainless Steel Front
- 1000\* Watts of Power
- 6 Minute Electronic Dial Timer
- Auto Reset Feature
- Capacity: 0.8 cubic feet
- "Grab & Go" Door Handle
- Bottom Energy Feed
- Fits One Half-size 6"-Tall Pan with Cover
- Interior Oven Light
- See-Through Oven Door
- Anti-Theft Equipped
- 3 Year Limited Warranty\*\*

\*\* **Limited**, model has 1<sup>st</sup> year parts and labour warranty, 2<sup>nd</sup> and 3<sup>rd</sup> year limited parts warranty on High Voltage transformer and magnetron parts only no labour. Please note 2<sup>nd</sup> and 3<sup>rd</sup> year is carry in service, no onsite warranty coverage for 2<sup>nd</sup> and 3<sup>rd</sup> year.

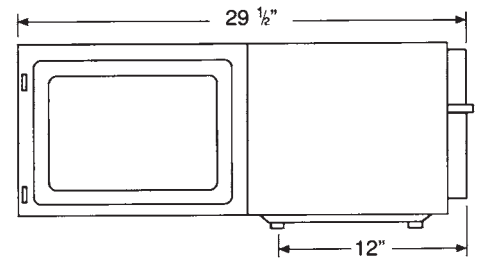
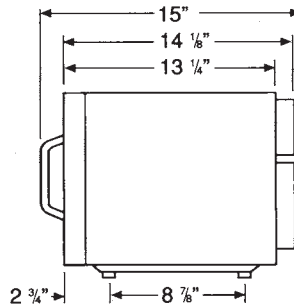
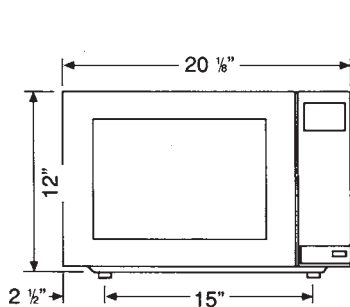

### Technical Specifications

**Power source:** 120V, 60Hz, Single phase

**Plug Configuration:** NEMA 5-15P



**Frequency:** 2,450MH z

**Required power:** 13.4 A

**Output:** 1000 Watts\*

**Outer dimensions in. (cm):** 20 1/8" (51.1) w x 16 1/8" (42.1) d x 12" (30.5) h

**Cavity dimensions in. (cm):** 13" (33) w x 13" (33) d x 8 1/8" (20.5) h

**Net weight:** 34 lbs. (15.4 kg)

**Shipping weight:** 39 lbs. (17.7 kg)

**Shipping box size in.(cm):** 24"(61) w x 18 1/4"(47.6) d x 14 3/4"(37.5) h, 3.8 cu.ft.

**Timer:** 6 Minute Electronic Dial with Auto Reset

### To specify a Panasonic Commercial Microwave Oven

The NE-1025 Commercial Microwave Oven meets or exceeds all safety performance and sanitation standards set for commercial food service microwave ovens.

Plus, oven shall have output power 1000 Watts\*, stainless steel front and bottom energy feed. Must be equipped with 6 minute electronic dial timer marked in 15 second increments, with auto reset feature instructions and cooking times visible on oven control panel, interior oven lamp, see-through window, door safety lock system.

*\*IEC705-88 Test Procedure. Specifications subject to change without notice*

# Panasonic

Panasonic Canada Inc., 5770 Ambler Drive  
Mississauga, Ontario, L4W 2T3 905-238-2267  
www.panasonic.ca